

EZ CLEAN CONVEYOR

Engineered, Manufactured and Installed to Your Specifications



EZ Clean Conveyor

- Retractable Tail Pulley for Belt Lift
- Continuous Belting, no seams
- Continuous Welds
- Conveyor disassembles without the use of tools for easy sanitation
- Wash through frame eliminates potential bacterial contamination
- Constructed using food approved UHMW
- Self-draining support frame eliminates standing water
- Motorized stainless steel drive pulley, eliminates external motor
- No bolts in product area
- All stainless steel frame construction
- All stainless steel sanitary foot pads and/or high grade castors

Optional CIP Spray Bar and/or Belt Scraper Available

Custom Built to Meet Customer's Needs

Motorized Stainless Steel Drive Pulley

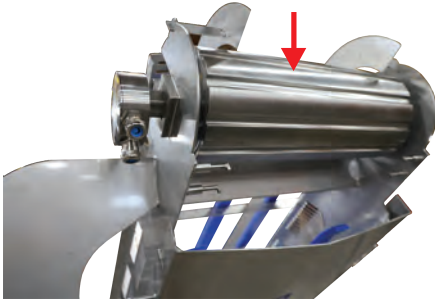

Pivots up for belt removal

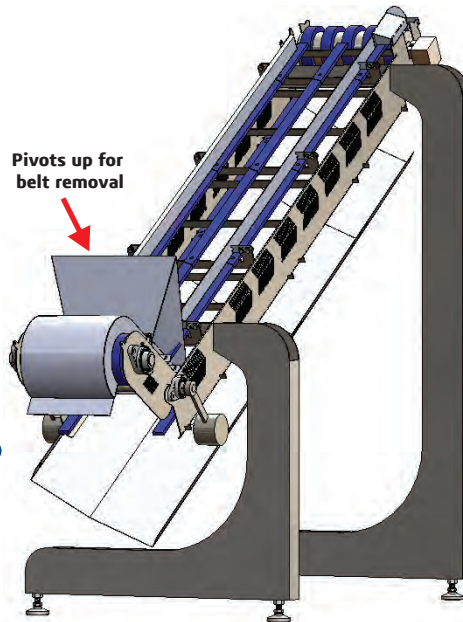

Retractable Tail Pulley for Belt Lift



Disassembles without tools

No enclosed tubes



equipment OF OREGON inc.

GEM can modify existing conveyors

2150 Progress Way Woodburn, OR 97071 Phone 503-982-9902 www.gemequipment.com
1010 N. Main Street Mt. Angel, OR 97362 Phone 503-845-9411 gem@gemequipment.com

CONVEYORS and CONVEYOR SYSTEMS

Designed to Optimize Performance and Productivity

GEM Equipment of Oregon, Inc. engineers, manufactures and installs custom food processing equipment in the United States, Mexico, South America, Africa, China and Europe. GEM Equipment builds a wide variety of custom conveyors and systems such as: sorting systems, accumulation, pallet, verticle and horizontal conveyors, belt, roller, chain, vibrating and other specialty conveyors for many industries.



peaches



soy bean



onions



french fries



chain

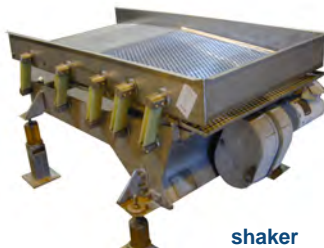

shaker



incline



radius



pears



cherries



hash browns



hazelnuts



In business since 1968

equipment ^{OF} OREGON inc.

2150 Progress Way Woodburn, OR 97071 Phone 503-982-9902 www.gemequipment.com
1010 N. Main Street Mt. Angel, OR 97362 Phone 503-845-9411 gem@gemequipment.com